

THE BROADCAST ENGINEERS' JOURNAL  
Ed. Stolzenberger, Editor  
116-03 91st Avenue Richmond Hill 18, N. Y.

Postmaster: If undelivered for any reason,  
notify sender, stating reason, on form 3547.  
postage for which is guaranteed.

F A GENRES WCBF-NEOA  
2232 E POWELL  
EVANSVILLE 14 IND  
S151

Sec. 562, P. L. & R.  
U. S. POSTAGE  
**PAID**  
New York, N. Y.  
Permit No. 2961

OFFICIAL PUBLICATION OF THE NATIONAL ASSOCIATION OF BROADCAST ENGINEERS AND TECHNICIANS

The Only Autonomous Union of Radio-TV Engineers & Technicians

*F. Stolzenberger*

# The Broadcast Engineers' Journal

WRGB TV Transmitter  
Installation

★★★

Official I.R.E.

Condensations of Technical  
Papers

★★★

NABET NATIONAL COUNCIL

MEETING: OCT. 9-15th.

SEPTEMBER 1949

Vol. 16

No. 9

SINCE 1924 OF, BY AND FOR  
**THE BROADCAST ENGINEER**

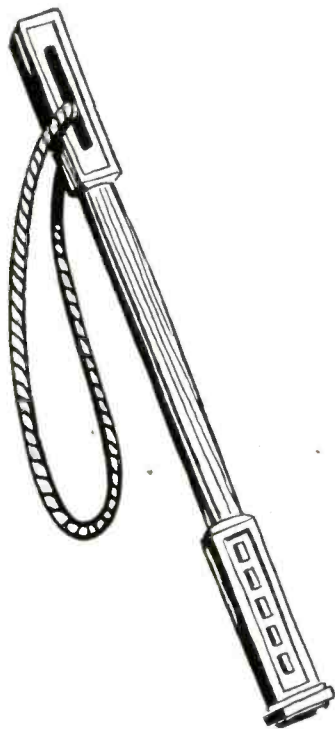

No scratch with ...  
**ADVANCE RECORDING BLANKS**

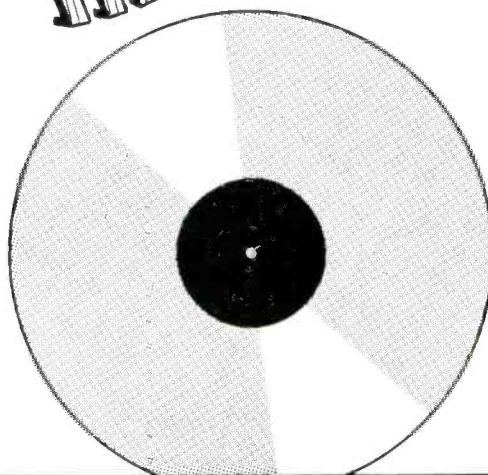

**Advance**  
Recording Products Company  
36-12 34th STREET • STILLWELL 4-7837 • LONG ISLAND CITY, N. Y.



# THE BROADCAST ENGINEERS' JOURNAL

ED. STOLZENBERGER, EDITOR AND BUSINESS MGR.

Editorial, Advertising and Circulation Offices:  
116-03 91st Avenue, Richmond Hill 18, N. Y.  
Telephone: Virginia 9-5553

VOLUME 16, No. 9



SEPTEMBER, 1949

Contents copyright, 1949, by NABET Publications

## TABLE OF CONTENTS

	PAGE
NABET President McDonnell's Message	2
Pertinent Topics from the NABET National Office	2
WRGB Television Transmitter Installation	3
Review of Current Technical Literature	7
Official IRE Summaries of Technical Papers	9
NABET's National Officers	10
Labor-Management News	11
ABC-New York News	14
New York News	15
Detroit News	16
Hollywood News	16
St. Lawrence News	17
Washington News	18
Rocky Mountain News	20

## THE BROADCAST ENGINEERS' JOURNAL

OFFICIAL PUBLICATION OF THE N. A. B. E. T.

Trustees—J. R. McDonnell, D. C. Shultis, Fred Smith, Fred H. Sperr,  
Ed Stolzenberger.

Secretary-Treasurer ..... H. E. HILLER

### ASSOCIATE EDITORS

Chicago	FRANK GENEREUX
Cleveland	EARL HOLL
Detroit	WALT BAKER
Dixie	SAM LILES
Engineering Chapter	D. C. SHULTIS
Hollywood	NORMAN DEWES
Hudson Chapter	GENE CLARK
Mohawk	JOHN F. McMAHON
New York	BOB ZWECK and GEO. HALVONIK
Omaha	LOUIS DE BOER
Philadelphia	R. J. WILKE
Pittsburgh	FRANK E. HENRY
Rochester, N. Y.	B. HOLLY
Rocky Mountain	GEORGE SOLLENBERGER
San Francisco	C. T. STEVENS
St. Lawrence, N. Y.	ALEEN A. CORBIN
Syracuse, N. Y.	PAUL K. NORTH
Washington	W. D. DEEM

The Broadcast Engineers' Journal is a privately printed monthly publication issued by NABET Publications. Address all communications to Publication office: E. Stolzenberger, 116-03 91st Avenue, Richmond Hill 18, L. I., N. Y. Telephone Virginia 9-5553.

Advertising rates and information supplied on request. Subscription, \$2.50 per year; \$4.00 for two years. Single copies, except Christmas Yearbook, 35c; Christmas Yearbook, \$1.00. All remittances in advance. Foreign: add postage. Back copies 50c, back Yearbooks, \$2.00.

Nothing appearing in The Broadcast Engineers' Journal shall be construed to be an expression of The Broadcast Engineers' Journal or the National Association of Broadcast Engineers and Technicians, but must be construed as an individual expression of the author or authors.

#### NATIONAL N.A.B.E.T. OFFICE

Room 1002, 421 Seventh Ave., New York 1, N. Y.

Mr. C. Westover, Executive Secretary

Wisconsin 7-0327

# National Association Broadcast Engineers and Technicians

OF, BY, and FOR  
THE  
BROADCAST  
ENGINEER

NABET is your democratic union, because  
NABET rank-and-file members control  
their union.

NABET means good trade-union practice.  
NABET is the progressive union in the  
Broadcast Field.

Contact any of the following officers for further information:

**J. R. McDonnell, Pres.**  
375 O'Farrell St., Room 101  
San Francisco 2, Calif.  
Ordway 3-8484

**C. Westover, Exec. Sec'y.**

**H. E. Hiller, Nat'l Sec-Treas.**  
**C. L. Gorsuch, Nat'l Rep.**  
421 7th Ave., Room 1002  
New York 1, N. Y.  
Wisconsin 7-0327

**Geo. Maher, National Rep.**  
80 E. Jackson Blvd. Rm. 543  
Chicago 4, Ill.  
Wabash 2462

**James H. Brown, Nat'l Rep.**  
6223 Selma Ave., Rm. 109  
Hollywood 28, Calif.  
Hillside 9311

#### Chapter Chairmen

**Chicago:**  
George Maher  
80 E. Jackson Blvd. Rm. 543  
Chicago 4, Ill.

**Cleveland:**  
Harold V. Brandt  
R. D. No. 2  
Brunswick, Ohio

**Detroit:**  
David B. Stewart  
1160 Seward St.  
Detroit 2, Mich.

**Dixie:**  
J. Willard Dean  
217 E. North St.  
Raleigh, N. C.

**Engineering:**  
D. C. Shultis  
75 Kenwood Road  
Riveredge, N. J.

**Hollywood:**  
Ben M. Doty  
3330 Charleston Way  
Hollywood 28, Calif.

**Hudson:**  
Frederick H. Sperr  
60 Wilson Street  
Hartsdale, N. Y.

**Mohawk:**  
Donald P. Morey  
12 Morningside Dr. RFD 6  
Schenectady 6, N. Y.

**New York:**  
Ed Stolzenberger  
116-03, 91 Avenue  
Richmond Hill 18, N. Y.

**Omaha:**  
D. Roy Glanton  
5500 Kansas Ave. Rt. 2  
Omaha 12, Nebraska

**Philadelphia:**  
R. J. Wilke  
4718 Chestnut  
Philadelphia, Pa.

**Pittsburgh:**  
W. C. Stuchell  
247 Cornell Ave.  
Pittsburgh 29, Pa.

**Rochester:**  
Edward Lynch, Vice-Pres.  
109 Wolcott Ave.  
Rochester 11, N. Y.

**Rocky Mountain:**  
Aubrey F. Blake  
2901 Eaton Street  
Denver 14, Colorado

**San Francisco:**  
Richard T. Parks  
10 Leroy Place  
San Francisco, Calif.

**St. Lawrence:**  
David H. Lane  
119 Maple St.  
Black River, N. Y.

**Syracuse:**  
Paul K. North  
631 Midland Avenue  
Syracuse 4, N. Y.

**Washington:**  
P. E. Anderson  
3108 Wellington Rd.  
Alexandria, Va.

#### Section Chairmen

**Atlanta:**  
Broughton W. Benning  
2715 Stewart Ave.  
Atlanta, Ga.

**Binghamton:**  
P. Sarantopoulos  
27 Exchange St.  
Binghamton, N. Y.

**Connecticut Valley:**  
George R. Townsend  
44 Lakeside St.  
Springfield 9, Mass.

**Elmira:**  
L. C. Hartman  
422 Fulton St.  
Elmira, N. Y.

**Fairmont:**  
O. C. Swisher  
632 Orr St.  
Fairmont, W. Va.

**Kingston:**  
J. G. McNelis  
304 Greenkill Ave.  
Kingston, N. Y.

**Louisville:**  
Kermit B. Smith  
1211 S. 6th St.  
Louisville, Ky.

**Mid-Hudson:**  
Robert Masterson  
6 Bush Avenue  
Newburgh, N. Y.

**Richmond:**  
Elmore Taggart  
2010 Seddon Rd.,  
Richmond 22, Va.

**San Diego:**  
J. A. Kemp  
1576 Acheson  
San Diego 11, Calif.

**and**  
Ralph Evans  
Route 1, Box 260  
Palm City, Calif.



## Pertinent Topics from the National Office

from

**C. WESTOVER**  
Exec. Secy., NABET

This office is in receipt of a letter from the Omaha Chapter, which indicates that the IATSE is up to its usual tactics. The following quote item unquote was mailed to WOW TV:

### "Movie Operators"

by Clyde Cooley

"They tell me television is coming to Omaha. That is fine. The IATSE Local has certain work in the television studios that is theirs. In some cities other locals have claimed this work. Our IA locals have made contacts to secure same in Omaha and we intend to do so. It is not the purpose of this column to enter into any controversy, but sometimes a word to the wise is sufficient.

Also may I ask the merchants to be sure of the Labor policies of a television station before patronizing same."

There was a second such article, apparently from the same source in much the same vein.

Roy Glanton, Omaha Chairman, has the proper answer to the IA's pleas. "If you want to get into TV, first learn something about it. Then, join NABET."

I must join Glanton in his feelings in this matter. NABET builds the house, then the IA wants to live there rent free. In this case, the IA makes the plea that "other locals" are claiming the IA's work. There is a slight error on the IA's part—NABET is not "claiming,"—NABET *has* the work and the IA *is* claiming. Possession is nine points of the law and NABET is not going to give up television, or anything else, because the stagehands' union wants in.

It is now being said that CBS has finally reached agreement with the IBEW. When a copy of that contract is available, we will make an effort to compare it to NABET net contracts.



## A Message to the Members of NABET

from

**JOHN R. McDONNELL**  
President, NABET

One more month to the NABET National Council Meeting (October 9, 1 P.M.). During September the Chapters should be having meetings for the purpose of discussing national issues and giving their respective Chairmen a true picture of the membership's wishes on these matters. At these meetings copies of the recent monthly reports should be available and discussed thoroughly by the membership.

It is with a great deal of pleasure that I announce that Jim Brown has accepted the office of National Representative (West Coast) effective July 1, 1949. Already Jim has cleared up a number of local problems in the Los Angeles area and promises to make a valuable contribution to NABET's activities. Jim has long been active in NABET affairs and at one time was President of the organization. His services and advice should prove invaluable.

It should be noted that a renewed effort is being made, on the part of a number of unions, to take over jobs that have been covered by NABET contracts for a number of years. Notably, at the moment, these efforts are being pushed by the Stagehands and the Teamsters. The jobs covered are important and it behooves every NABET member to be on the alert to prevent any incursion on NABET's jurisdiction by another union. A loss in any one of these areas could ultimately mean your job.

There has been perhaps an understandable slackening of NABET activity, in some areas, for the past few months due to the vacations. However, with the advent of fall and the availability of the entire membership, it is to be sincerely hoped that every member will take an increased interest in NABET and do his utmost to make a worthwhile contribution to union affairs. It is only by concerted activity of an informed, aggressive membership that NABET, or any union, will make real progress.

Sincerely,

**JOHN R. McDONNELL,**  
*President—NABET.*

FOR INFORMATION

ABOUT

**NABET**

CONTACT

ANY OFFICER

★ SEE PAGE 1 ★



NABET IS PLEASED TO ANNOUNCE

the appointment of

**MR. JAMES H. BROWN**

WEST COAST

NABET NATIONAL REPRESENTATIVE

6223 Selma Avenue  
Hollywood 28, Calif.

Room 109  
Hillside 9311



# WRGB TV Transmitter Installation

By DORR CLINTON WILSON

Recently completed is the new low band television transmitter installation of the General Electric Company's television outlet, WRGB, in Schenectady, New York.

The transmitter building is located about twelve miles south of Schenectady in the Helderberg Mountains. This location provides an exceptionally good service area. Not only is the Tri-City area (Albany, Troy and Schenectady) served, but good reports have been received as far as fifty miles north and south of Albany along the Hudson River Valley.

The transmitter building (photo No. 1) is about 130 feet by 30 feet. A General Electric equipped kitchen and four bunk beds, features incorporated into the building, find use at various times during severe winter weather. In addition to the television transmitter WRGB, the General Electric frequency modulation transmitter, WGFM, is housed in the building. Also in the building is a large workshop. Water for the heating system and bathroom is drawn from a driven well in the building. Drinking water is brought in bottles from the studios in Schenectady. The building is heated by two General Electric oil heaters which provide steam heat throughout the building. Two aux-

iliary generators are provided for supplying power in case of failure of the commercial power. One of these is a 5 kva generator and is gasoline-powered. The other is a 50kva Diesel generator. The two generators are large enough to handle all the power demanded by the tele-

vision transmitter and the FM transmitter, plus all the lights and the heaters.

Both visual and aural signals are brought to the transmitter via radio relay links. As shown in photo No. 1 there are two parabolic reflectors to the right on the roof of the building. These are used for the 2,000-megacycle visual relay link. One of the reflectors is rotatable and can be used for remote pick-ups direct from the program source to the transmitter.

A 2,000-megacycle relay link is utilized to bring programs from New York City to Schenectady. The visual portion of the signal is sent from the Empire State Building to the first tower in the relay system which is located at Beacon, New York. The second and third towers are located at Round Top, New York, and in the Helderbergs, respectively. The tower located in the Helderbergs shoots the signal to the Schenectady studios. The parabolic receiving reflector mounted on the structure of the main television transmitting antenna, shown in photo No. 2, is directed to the relay tower located in the Helderbergs and is used in emergencies to by-pass the studio in case of failure of the studio transmitter or receiver. One other method of receiving video at the transmitter is provided by

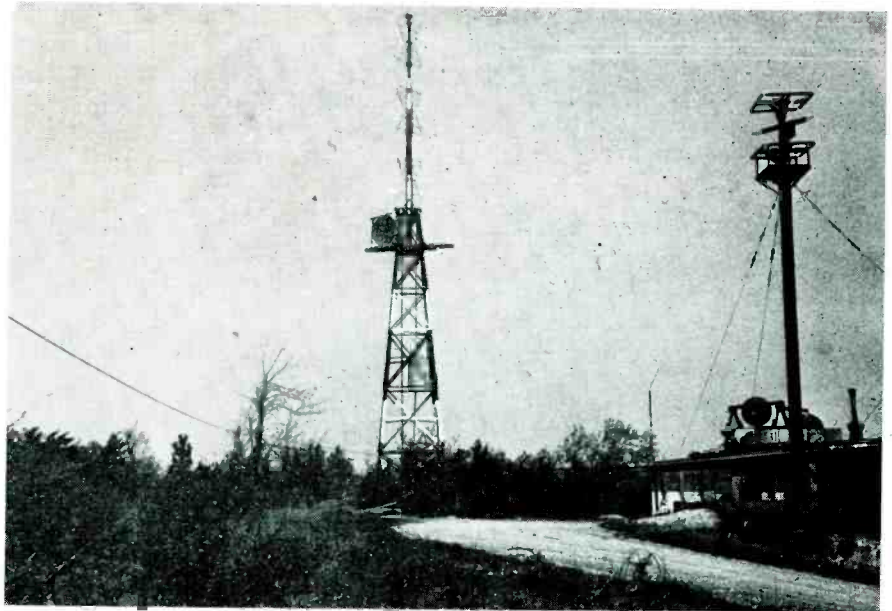

WRGB Transmitting Antenna Tower



WRGB Transmitter Building

the portable remote equipment (in a Mobile Unit) operating on about 7,000 megacycles. Signals can be received from the Mobile Unit from most spots in the area.

The television transmitter and operating console are shown in photo No. 3. By placing the console directly in front of the transmitter, the functions of Control Operator and transmitter Operator are combined in one man. Six meters are mounted on the top panel across the front of the transmitter. These meters have five-inch faces, lettered white on

three stages of the visual transmitter are water-cooled.

The transmitter is divided into three cubicles; two are for the visual transmitter, and the third is the aural transmitter. The front and rear doors of the visual transmitter are interlocked; only the rear doors of the aural transmitter are interlocked. The rear doors of all cubicles have glass panels as shown in photo No. 4, permitting observation of the various units without opening an interlock.

The aural transmitter is a sister to the

General Electric 3-kw frequency-modulation transmitter. Its power output is 2.5-kw. This transmitter of course employs the phasitron system of modulation, in which modulation is divorced from the frequency control and tends towards greater frequency stability and improved frequency modulation characteristics. The rest of the transmitter is pretty straightforward. As shown in figure 1, the output of the modulator and frequency multiplication panel is fed to an 815. The 815 feeds an 829B and this stage feeds a pair of GL-5D22's. The output of these GL-5D22's feeds a pair of GL-7D21's which comprise the final amplifier stage. Plate voltage for the final is obtained from six 8008's connected in a conventional three-phase full-wave rectifier circuit with an L-C filter. This transmitter is somewhat different from the regular 3-kw FM transmitter in that plate voltage for the 5D22's is obtained from a voltage divider across the final plate-voltage supply. This voltage is obtained from a pair of 886's in the 3-kw FM transmitter. Another difference is that the screen voltage for the final stage is obtained from 5R4GY's mounted on a panel and accessible from the front of the transmitter. In the 3-kw FM transmitter, this screen voltage is obtained from a pair of 866's mounted in the PA cabinet and accessible only by opening the rear doors which are interlocked.

Another feature of the new aural transmitter is a pre-emphasis unit with toggle switches which allows for balanced or unbalanced input, and for either 150- or 500-ohm termination.

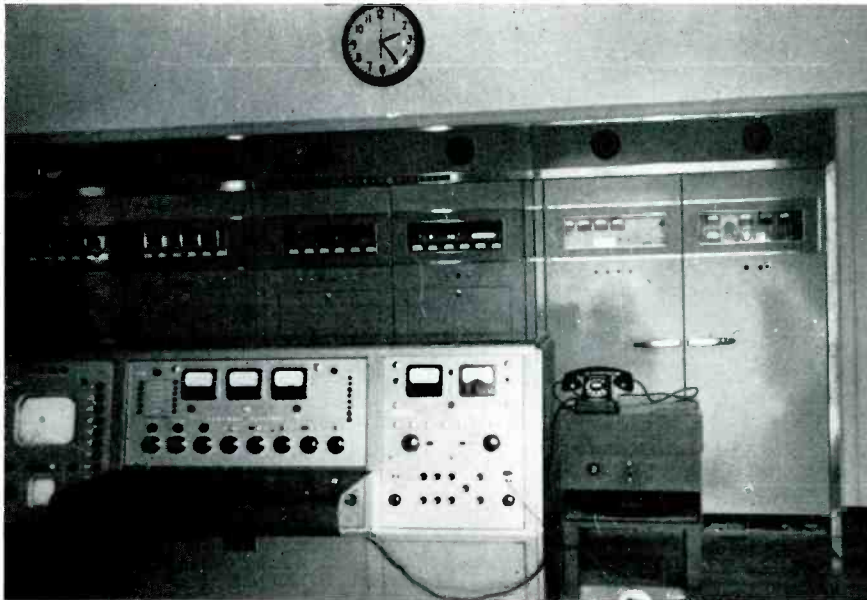

Operating Console and Transmitter

black. Three spot-lights over the console provide illumination for these meters and the front of the transmitter. Due to the large meters and the spots, the transmitter operator can make peak-power adjustments from the console and observe final plate current and peak-power meters without leaving the console.

Cooling facilities are at the rear of the transmitter. These facilities include a water cooling system and a forced air cooling system. The entire transmitter and cooling system are housed in a louvred, sound-proof structure. Not only is the noise of the cooling motors cut down by the sound-proof construction, but better air temperature control is obtained. The air from the blower enters the transmitter through channels in the concrete foundation, and the warm air is exhausted through a duct with a damper which will pass the air out through the top of the building in warm weather or back out into the transmitter room in cold weather. The water cooling system is small but adequate. Only the final

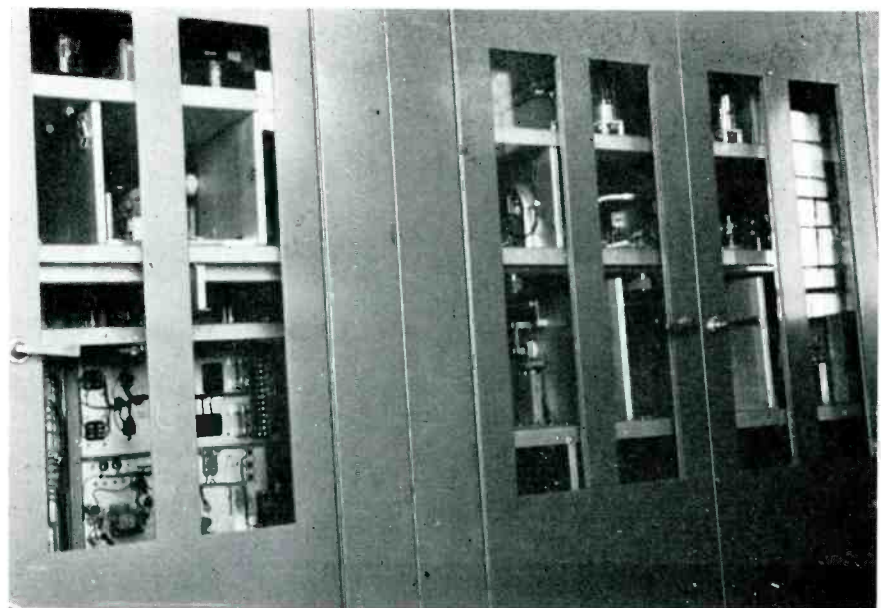

View of Rear of Transmitter Showing Glass Panels



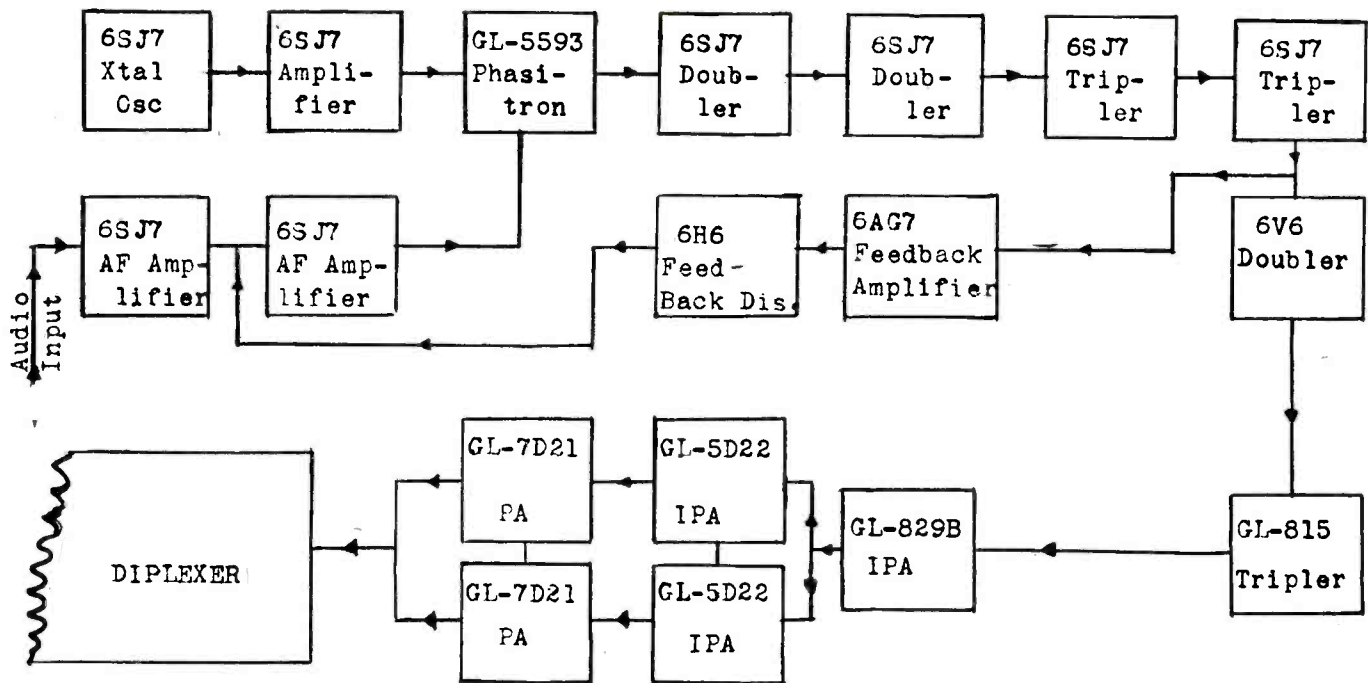

Fig. 1.—Block Diagram of Aural Section of WRGB Transmitter

The visual transmitter is comprised of two cubicles. The first cubicle contains the crystal and RF exciter, the modulator, the modulated stage, two stages of amplification and associated power supplies. In addition, the first cubicle contains a built-in sweep generator for alignment purposes. The second cubicle contains three stages of amplification. Included in this cubicle is the high-voltage supply and two bias supplies. In the bottom of the cubicle are mounted the high-voltage transformers and associated filter reactors.

The sweep generator (first cubicle) output is brought out to the front panel to two amphenol coaxial jacks. Coaxial jacks are provided for each stage of amplification through the transmitter and thus the sweep output may be fed to each of the individual stages for circuit alignment. These jacks feed through 70-ohm flexible coax to the individual stages. These lines are terminated at each respective stage in a resistor-germanium crystal combination. This provides a means of patching a test-

oscilloscope in for checking the performance of each stage separately. Utility outlets are provided throughout the transmitter for servicing and auxiliary lighting when required. Supervisory lights appear on the front of each door. These lights provide indication as to which stage or circuit has an overload or which door interlock hasn't been closed.

The visual transmitter circuit layout is shown in block form in figure 2. The transmitter employs crystal-controlled frequency. The crystal operates on one-quarter video carrier frequency. The

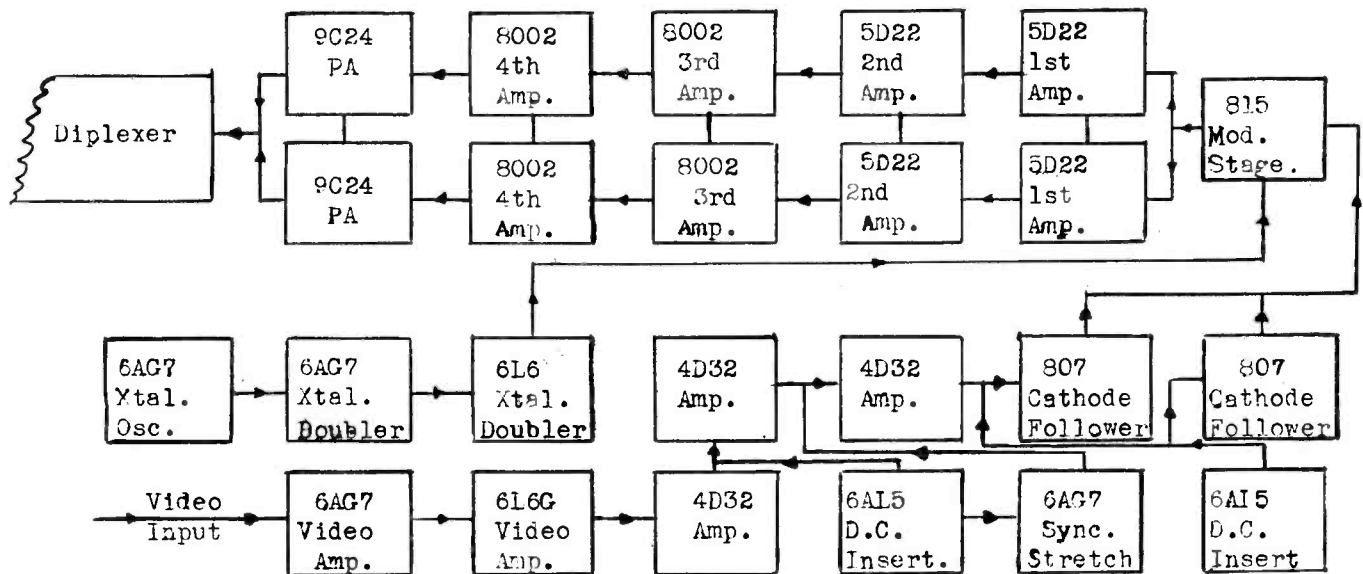
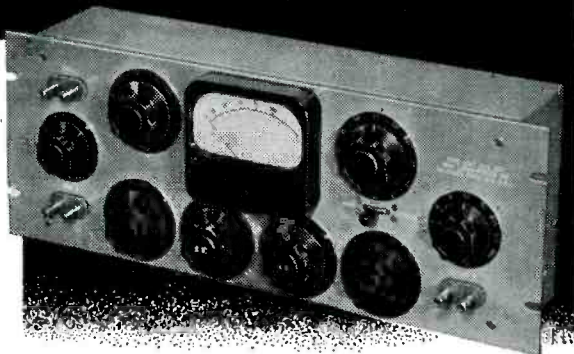

Fig. 2.—Block Diagram of Visual Section of General Electric 5KW Television Transmitter

# NEW... Improved Wiring Eliminates Leakage

## TYPE 12AT & TYPE 12ATK (KIT) TRANSMISSION MEASURING SET

Range: 1'1 db. in 0.2 steps.  
Frequency resp.: 0.1 db. from 0 to 20 kc.  
Accuracy: 0.1 db.  
Impedance, load section: 4, 8, 16, 50, 150, 200, 500, & 600 ohms.  
Impedance, transm. set.: 50, 150, 200, 500 & 500 ohms.  
Reference level: 1mw. into 600 ohms.  
Circuit: "T", unbalanced.  
Attenuators: 10x10, 10x1 & 5x0.2 db.  
Load carr. cap.: Transm. sect. 1 w. Load section 10 w.



A precision Gain Set with specially developed wiring that permits no troublesome leakage and provides improved frequency characteristics. Available completely assembled, or in kit form—which permits the sale of a high accuracy instrument at a low price.

WRITE FOR DESCRIPTIVE BULLETIN



Manufacturers of Precision Electrical Resistance Instruments  
PALISADES PARK, NEW JERSEY

crystal frequency is multiplied by two doubling stages. The RF carrier frequency is applied to the control grid of the 815 stage. The video from the console is fed into the following sequence in the modulator: 1 stage 6AG7; 1 stage 6L6; 3 stages GL-4D32 and two 807's operated in parallel. The output of the modulator is taken from the parallel cathodes of the 807's. The modulator output (video) is fed to the plate of the 815 modulated stage and the plate circuit is so tuned that the composite signal fed to the grid of the first stage of 5D22's is practically single side-band. Another stage of 5D22's follows the first. From the second 5D22 stage, the signal is fed to the filament of the first stage of 8002's. The final three stages of the transmitter are operated grounded-grid; this alleviates the necessity for neutralizing. Another stage of 8002's follows the first, and the final amplifier is a stage of 9C24's. The GL-9C24 is a recently developed high-frequency triode. As stated before, this stage is water-cooled. In addition to water-cooling the anode, the filament of the GL-9C24 stage is water-cooled. The out-

put of the transmitter is matched to a 51.5-ohm concentric, one and five-lengths inches line. The output of both the visual and aural transmitter are fed to a diplexer unit which provides proper termination and phasing of the two signals, which are then fed to a three-bay superturnstile antenna array.

Transmitter control is accomplished by the GE model TC-13-A console. Here are assembled all the controls necessary for the proper operation of the transmitter. From the center of the console to the left are located the controls and monitoring facilities for the visual portion of the channel. Transmitter controls associated with the visual portion of the picture are: video input channel selection and attenuation; peak power control; video gain control, and RF gain control. A three-stage video amplifier is located behind the center panel of the console to provide a means for controlling the video signal applied to the modulator in the transmitter. The extreme left-hand side of the console houses the ten-inch picture monitor tube and the five-inch waveform monitor tube. Video signal for these

two tubes is received from demodulators which receive RF from probes in the concentric line output of the transmitter just prior to the diplexer. A system of six pushbuttons is provided for each of the monitor C-R tubes. On each C-R tube, a selection of either of the demodulators, transmitter input, modulator output, and either of two video program lines is provided. This affords a means for rapidly checking various key points in the video system. The right-hand side of the center section of the console contains the controls associated with the aural transmitter. Included in these controls is the program fader, the line fader, monitor amplifier gain control, microphone fader, selection of either of two audio program lines, and selection of studio or local turntable and microphone circuits. On this same panel is located a pushbutton system by use of which the input to the audio monitoring amplifier may be changed to select any of seven inputs, giving a rapid means of checking the audio signal from the receiver output through the program amplifier and to the transmitter output. On the extreme right-hand side of the console are located the ON-OFF pushbuttons for the control circuits of both the visual and aural transmitters. A turntable selector switch and fader are also located on this panel. Meters provided on the console are the visual transmitter center frequency meter, the aural transmitter center frequency meter, the aural transmitter percentage modulation meter, a standing-wave-ratio meter for the transmission line of the visual transmitter, and a VU meter across the aural transmitter input. The rear of the console, behind interlocked doors, contains a program amplifier, a monitoring amplifier, a patch panel, and power supplies for the video amplifier and various low-voltage circuits in the visual monitor.

The combination of the console and the transmitter provides a symmetrical, neat arrangement for efficient handling of television programs as received from the studio or other source.

There are seven men on the transmitter staff. James Billings is the engineer in charge of maintenance and repair, under Mr. B. W. Cruger, assistant to the Chief Engineer for General Electric Broadcasting. Horton C. Mosher (W2DEL), William J. Barnes (W2GM), Dorr C. Wilson, Carl Youngs (W2ZMA) and John McMahan (W2ZSJ) are the regular transmitter operators. Arthur Reardon is the antenna and building maintenance man.





# Review of Current Technical Literature

By Lawrence W. Lockwood

## **Audio Engineering—May 1949**

**A Simplified Transmission Set—J. Smith Jr., C. Scott**  
Technical details of a new instrument designed to provide accurate gain measuring facilities.

## **Construction of a Broadcast Station Record Turntable—H. Edison, Jr.**

A turntable housing of professional quality which may be constructed at a reasonable cost to provide record reproduction facilities suitable for the most exacting uses.

## **The Bell System Technical Journal—April 1949**

### **Delay Equalization of Eight Kilocycle Carrier Program Circuits—C. Dagnall, P. Rounds**

This paper describes the equalization of delay in 8 kc program systems transmitted over broad band carrier telephone facilities.

### **A Precise Direct Reading Phase and Transmission Measuring System for Video Frequencies—D. Alsborg, D. Leed**

Description of a method of test and type of instruments used by the phone company for video signals.

## **Communications—February 1949**

### **A TV Monitor Receiver—F. Grace**

Receiver which can be located in high signal transmitter area, features protection against overloading by strong signals, and insensitivity to RF fields in which it may be placed.

### **Automatic Bulletin Alarm—George Ing**

Device automatically signals arrival of bulletin via a visual signal in control room obviating need for watch in teletype room.

## **Communications—March 1949**

### **The WMAL TV Mobile TV Unit—F. Harvey, E. Hilburn**

Airconditioned mobile unit, designed for speedy setup, convenience of operation and rapid and efficient maintenance.

### **Producing Broadcast Quality Telephone Recordings—A. Kelly**

Application of a telephone recorder connector across station trunk lines and use of disc or tape recorder provides high quality telephone recordings and permits rapid processing of telephone interview recordings for spot news broadcasts.

### **Monitoring Rectifier for AM Stations—R. Lambert, Jr.**

System adapted from conventional voltage doubler has a

balanced output suitable for use with monitoring amplifier having bridging input impedance of 20,000 ohms balanced to ground. Provides large audio output with relatively low distortion.

## **FM Proof of Performance Measurement Techniques—F. Talmage**

How to use Measurement equipment (audio oscillator, attenuator panel, noise and distortion meter, and rf rectifier) and secure required performance data for the FCC.

## **FM TV—April 1949**

### **Fixed Frequency FM Tuners—F. Spindell**

Browning tricast series included monitor type and tone controlled models designed to produce revenue for FM stations.

## **Obsolescence of TV Receivers—**

The economic problems of UHF television do not indicate any early obsolescence in current VHF receiver designs.

## **FM and TV Antennas—G. Kearse**

More planning and less guessing are needed in selecting the design.

## **Subminiature IF Amplifiers—R. Henry and G. Shapiro**

Progress report from the Bureau of Standards on techniques of subminiature design and manufacturing.

## **FM TV—May 1949**

### **Klystrons for FM—W. Henderson**

The Sperry SRL 17 for fm transmitters and receivers on 920 to 990 mc.

## **FCC Plan for TV Expansion—Hon. W. Coy**

By the use of low cost repeater installations operated with minimum staffs, TV coverage can be expanded greatly.

## **Progress on UHF Television—Dr. T. Goldsmith, Jr.**

A review of equipment which has been used for tests on UHF and the problems which remain to be solved.

To Page 8.

## RADIO-TV MEN

**NABET is the only Autonomous union of Radio-TV men. That is why NABET is the ONLY radio-man's union that is fighting the IATSE. Write the NABET National Office for NABET-Authorization cards. IBEW is NOT fighting IATSE's demand for your radio-TV job. Help NABET help YOU!**

### SUBSCRIPTION BLANK

THE BROADCAST ENGINEERS' JOURNAL  
116-03 91st Avenue, Richmond Hill 18, N. Y.

Gentlemen: Please enter my subscription to The Broadcast Engineers' Journal to start with the next issue.

Name..... (Station.....)

Address .....

City, P. O. Zone, State.....

Check attached for  \$2.50, 1 year;  \$4.00, 2 years.

Climaxing 15 years experience in training **PRACTICAL ENGINEERS** . . . we announce completely **NEW** and **MODERN AM - FM - TV STUDIO, TRANSMITTERS, and IMAGE ORTHICON CAMERA CHAIN** . . . specially designed and planned to give the student the practical experience needed to be a real asset to an engineering staff.

Request our descriptive catalog describing at length the specialized training and equipment offered here.

Our Placement Department will furnish data on graduates upon request.

*Phone or Wire Collect*  
Telephone **TE**mple 3-4620

## **RADIO ELECTRONIC TELEVISION SCHOOLS**

3730 Woodward Avenue, Detroit 1, Michigan

## **CAPPS\***

SAPPHIRE is, and has always been, the only material for making cutting styli for high class recordings.

CAPPS\* Patented Sapphire Styli (2187512) are the original and accepted standard for high class professional acetate recordings.

*Imitated but not equalled*

**FRANK L. CAPPS & CO., Inc.**

244 W. 49th STREET NEW YORK CITY  
Telephone **CI**rcle 6-5285

\*Reg. U. S. Pat. Off.

### **Proceedings of the IRE—April 1949**

**Temperature Variations of Ground Wave Signal Intensity at Standard Broadcast Frequencies—F. Gracely.**

Variations of ground wave signal intensity at standard broadcast frequencies appear to be more closely related to changes in temperature than to any other single commonly observed meteorological measurement. General relationships deduced from all paths are combined in a nomograph chart showing intensities relative to the peak value for various frequencies, path lengths, and temperatures.

**Transient Response Equalization Through Steady State Methods—W. Kessler**

This paper describes a steady state method for matching the pulse-response characteristics of two or more networks using only a sinusoidal signal generator and a cathode ray oscilloscope.

### **RCA Review—March 1949**

**Standardization of the Transient Response of Television Transmitters—R. Kell, G. Fredenall**

Standardization of the square wave response of a television transmitter is suggested on the basis of a comparison of the response of a standard monitor to square wave signals generated by the transmitter and the calibrated response of the monitor to a double sideband television signal modulated by a square wave.

**Phase and Amplitude Equalizer for Television Use—E. Goodale, R. Kennedy**

A phase and amplitude equalizer is described which permits considerable improvement to be made in the performance of a transmission system whose overall response has been deteriorated by poor phase and amplitude characteristics.

**Ultrafax—D. Bond, V. Duke**

An experimental high speed system of record communication (capable of transmitting over a million words per minute) known as Ultrafax is described.

### **Tele-Tech—April 1949**

**Radio TV Must Make Way for Young Engineers—I. Coggeshall**

Youthful energy essential for new inventions and engineering advances in radio electronic art—Today's technical complexities best utilized by 25-30-35 year groups.

**Pulse Cross Generator Applied to TV Production Test Equipment—R. Burr**

New equipment facilitates TV receiver quality control by providing continuously monitored test signals whose known characteristics conform with FCC standards.

**New Portable Tape Recorder Performs With Studio Quality—W. Stewart**

Highly adaptable to broadcast recording requirements, unit features automatic speed frequency equalization.

### **Tele-Tech—May 1949**

**Lighting Requirements of Television Studios—R. Blount**

Camera equipment limitations, locale variations, necessitate carefully controlled light sources for superior picture quality.

**Voltage Multiplier Systems in TV Receivers—M. Mandl, N. Sher**

Typical circuits shown and discussed.

**Video Recording Technics—G. Gordon**

Current engineering practice favors using 16 mm equipment in photographing programs directly off CR tubes.

**Noise Figures for Receiver Input Circuits—P. Sulzer**

Analyzing six different circuits commonly employed in UHF receivers and discussing suggested applications for each type.



# Official I.R.E. Summaries of Technical Papers

Presented at the 1949 IRE Convention—continued from last month

## SYMPOSIUM: NUCLEAR SCIENCE

Chairman, L. R. HAFSTAD

(Division of Nuclear Reactors, Atomic Energy Commission, Washington, D. C.)

1. **The Fundamental Particles.**  
DONALD J. HUGHES, *Argonne National Laboratory, Chicago, Ill.*
2. **The Detection and Measurement of Nuclear Radiation.**  
HOWARD L. ANDREWS, *National Institute of Health, Bethesda, Md.*
3. **Biological Effects of Radiation.**  
KARL HOUGHTON, *Armed Forces Special Weapons Project, Washington, D. C.*
4. **The Application of Nuclear Radiation to Industry.**  
JOHN R. MENKE, *Nuclear Development Associates, Washington, D. C.*

Engineers in the electronic industry are assuming an ever-increasing responsibility in the development and production of equipments related to the science of nuclear physics. Their participation is still in its early stages, and is still limited to a small fraction of the tasks which invite their attention. So that those in the electronics industry may see a broader horizon to the possibilities of work in the atomic energy field. The Institute of Radio Engineers has organized a symposium, which, many may say, is in advance of its proper time.

For engineers and scientists associated with electronics, exposure to a discussion of nuclear particles on a broad base may seem a little premature, but only if the complete picture is presented can we hope to enlist the full cooperation of their services. Dr. Hughes, one of the foremost of our young American physicists, will discuss the fundamental particles and present the basis underlying the interrelation of nuclear particles. Following this, Dr. Andrews and Lt. Col. Houghton will set forth an explanation of how these fundamental particles are measured, and what their effect is on the human organism.

Having thus described the nuclear particles as to what they are, how they are measured, and what they do, the symposium concludes with Mr. Menke's survey of the practical applications to which these can be put in industry and research.

## TELEVISION I

Chairman, AXEL G. JENSEN

(Bell Telephone Laboratories, Inc., Murray Hill, N. J.)

63. **A Unidirectional Reversible-Beam Antenna for Twelve-Channel Reception of Television Signals.**

O. M. WOODWARD, JR., *RCA Laboratories Division, Radio Corporation of America, Princeton, N. J.*

The present commercial channels assigned for television range from 54 to 88 Mc and from 174 to 216 Mc. This paper describes a unidirectional receiving antenna which is effective over these channels without adjustment.

The array is made up of dipole elements which themselves maintain desirable characteristics over the entire television range. These elements are united by a simple transmission-line network to yield a directive pattern.

The antenna maintains a high front-to-back ratio over all twelve channels, and is particularly useful in fringe areas where it is necessary to reduce co-channel interference.

The directional beam is reversed on any channel by a simple switch which transposes a single transmission line.

64. **A Method of Multiple Operation of Transmitter Tubes Particularly Adapted for Television Transmission in the UHF Band.**

GEORGE H. BROWN, WENDELL C. MORRISON, W. L. BEHREND, AND J. G. REDDECK, *RCA Laboratories Division, Radio Corporation of America, Princeton, N.J.*

A combining network has been developed which allows two transmitter tubes to be operated simultaneously into a common load without interaction between tubes and without reduction in bandwidth. A theoretical analysis is presented which shows that the necessary balancing adjustments are not critical. A pair of tubes and a combining network may then be considered as a unit, and again combined with other units to provide a transmitter with a large number of tubes in multiple operation.

A complete television transmitter with a carrier frequency of 850 Mc has been developed, using four tubes in multiple. The physical arrangement and the operating characteristics of this transmitter are discussed.

65. **Transient-Response Tests on the WPTZ Television Transmitter.**

R. C. MOORE, *Philco Corporation, Philadelphia, Pa.*

In order to determine the performance of the new WPTZ transmitter, a program of transient tests was undertaken utilizing the procedures recommended by a Subcommittee of the RMA Television Sys-

tems Committee. The equipment consists of a 100-ke square-wave generator with steep wavefronts, a wide-band oscilloscope, and a VSB monitor-receiver of prescribed characteristics. Following a determination of the monitor transient response, the transient response of the transmitter and monitor together is found. From these results the behavior of the transmitter is deduced. The distortions measured at WPTZ due both to the rf and vf circuits will be discussed. Compensation by predistortion with vf networks will be described.

66. **Television Transmitter Carrier Synchronization.**

R. D. KELL, *RCA Laboratories Division, Radio Corporation of America, Princeton, N. J.*

Laboratory tests have indicated that a substantial reduction in co-channel interference between television stations can be obtained if the carrier frequencies are synchronized. Actual tests using television stations in New York and Washington confirm the laboratory observations.

Signals from New York and Washington are compared in a phase discriminator at the output of two receivers located in Princeton. The information regarding relationship of the two carriers is carried as frequency modulation of a 1,000-cps tone by telephone line to New York. The frequency shift of this tone is utilized to change the frequency and phase of the New York carrier to maintain a fixed phase relationship between the New York and Washington carriers as observed at Princeton.

67. **Television by Pulse-Code Modulation.**

W. M. GOODALL, *Bell Telephone Laboratories, Inc., Deal, N. J.*

Fundamental experiments to reveal the effects on television of time and amplitude quantization have been made. The experiment consisted in step-sampling the television signal at various rates up to ten million times per second, the coding of each level by means of a binary code, the reconversion of the code signals to quantized television, the display of the resulting signal on standard television monitoring devices, and the comparison with an unquantized signal. The relationship of the number of digits needed to the noise level, the picture quality, and other factors is discussed. Studies with this ex-

To Page 19



**C. Westover**  
Executive Secretary

---

---

**NABET  
NATIONAL  
OFFICERS**

---

---



**J. R. McDonnell**  
President, NABET



**Harry E. Hiller**  
National  
Secretary-Treasurer  
NABET



**George Maher**  
Mid-West  
National  
Representative  
NABET

**Cliff Gorsuch**  
Eastern  
National  
Representative  
NABET



**James H. Brown**  
West Coast  
National  
Representative  
NABET





# LABOR - MANAGEMENT NEWS

## WORKERS OVER 45 FIND EMPLOYMENT SCARCE

Older workers—45 and over—have had a relatively lower employment rate since the end of World War II than younger workers, but when they become unemployed they have much difficulty in finding new employment, according to a survey recently completed by the Bureau of Employment Security (Federal Security Agency).

The BES study, based on findings in six representative communities, points out that during the high level of employment during the past two years, older workers seeking employment were fewer in number than younger workers.

As of April 1949, the study asserts, there were 21,300,000 workers 45 years of age and over in the civilian labor force, a gain of 800,000 since 1947. Workers 45 and over accounted for 35 per cent of the civilian labor force in 1949 and for 34.6 in 1947.

The unemployment rate for all workers in the civilian labor force in April 1949 was five per cent, while the unemployment rate for workers 45 to 54 was 3.7. For workers 55 to 64 and 65 and over it amounted to 4.1 and 4.7 respectively. The unemployment rate for workers under 25, the group containing the largest number of new entrants into the labor market, was the highest.

The study emphasizes that, although improved medical science is increasing the longevity of the population and the number of older workers and resulting in higher levels of physical ability on the part of older workers, age restrictions continue to be operative against them.

### Capacity Disregarded

"It is quite customary to restrict hiring of new workers to those under 40 or 45 years of age, without taking into account the physical and mental capacity of the individual worker," the study asserts. "This arbitrary definition of older workers unquestionably does a great disservice to those who have passed this age but who continue to be as well or better qualified by experience and physical and mental capacities as the younger workers. While workers past 45 have difficulty in securing employment because of their age, the Social Security Act provides retirement benefits to those who have passed their sixty-fifth birthday.

"A gap of 20 years therefore exists, during which workers face increasing uncertainty of employment because of age without being eligible to benefits linked to their age."

### Findings Summarized

A partial summary of the BES study indicates:

1. In both tight and loose labor markets, older workers once separated from employment take longer to find jobs. If not reemployed in their regular work, they are nearly always downgraded and receive less pay.
2. Older workers apparently exhaust unemployment insurance benefit rights sooner than younger persons.
3. The increased number of establishments covered by collective bargaining agreements having seniority provisions has apparently reduced the extent to which older workers are laid off.
4. Job opportunities for older workers vary according to

occupation, industry, and worker characteristics. In service occupations there are fewer restrictions against the hiring of older workers, but for white-collar and semiskilled occupations the age restrictions are quite rigid.

5. As unemployment increases, employer specifications with respect to age are tightened, and the percentage of older workers among job seekers rises. In a very loose labor market, older workers become overrepresented among job seekers, and employers with a much larger labor reserve to choose from become increasingly reluctant to hire those in the upper-age group.

---

## Courts Back NLRB On Pension Plans

Pension and retirement plans are no longer "fringe" issues, but are clearly within the circle of subjects on which employers are required by law to bargain collectively with their employees.

The status of pension plans was established by the recent action of the United States Supreme Court in refusing to review a decision of a United States Court of Appeals upholding an order of the National Labor Relations Board. It held that an employer must bargain with his employees on such plans if the employees request it.

It was the first time that the question had been brought before either the Board or the courts.

The Supreme Court's action was taken in a case involving the Inland Steel Co. of Chicago and the United Steelworkers of America. The Board, however, conditioned its order on the Steelworkers' compliance with the non-Communist affidavit requirements of the Labor Management Relations Act.

In this case, a four-member majority of the Board ruled that pension plans come within the scope of the provision of the act which makes it mandatory for both employers and unions to bargain collectively "in respect to rates of pay, wages, hours of employment, or other conditions of employment." The majority opinion was signed by Chairman Paul M. Herzog and Board Members John M. Houston, James J. Reynolds, Jr., and Abe Murdock. Board Member J. Copeland Gray dissented.

In the opinion, the majority declared:

"Realistically viewed, this type of wage enhancement or increase, no less than any other, becomes an integral part of the entire wage structure, and the character of the employee representatives' interest in it, and the terms of its grant is no different than in any other case where a change in wage structure is effected."

In two other decisions coming soon after the ruling in the Inland case, the Board applied the same reasoning to group insurance. The Board ruled that various types of group insurance, like pension and retirement benefits, constitute an indirect part of wages as well as part of the "conditions of employment."

---

---

## Switch To NABET — Today'

# ETERNAL VIGILANCE — A LABOR DAY REMINDER

Labor Day is coming up. It won't be long.

Then comes fall and soon after that, winter.

What will the country be facing this fall and winter? Will the economic pendulum swing high, or will it swing low?

The guesswork economists tell us all manner of things. Some guess high; some guess low; some guess a sort of rolling series of waves along about mid-way.

But anyway, Labor Day is coming up and it is well worth considering.

Labor Day was set aside as something more than just another holiday. It was set aside to mark the dignity of labor, the importance of labor as a part of our national life, the force of Labor in helping to shape the nation's destiny.

And mark this well, Labor means organized labor, for that is the only Labor with which anyone can have a word or strike a bargain.

\* \* \*

You can't talk to unorganized labor, for in every case, unorganized labor is just one man all to himself, bound to nothing, adhering to nothing, claiming kinship with nothing, going nowhere—just a guy pitifully all alone.

Unorganized labor never staged a parade, for you have to have some organization before you can even have a parade.

You never saw unorganized labor picket a plant, because you have to have some organization before you can organize a picket line.

The organization you have may not be orthodox, but it will be some form of organization and it's pretty sure that as time goes on and lessons are learned, the pathway will lead to true union organization.

It is a matter of history that many a company union, formed at the outset by the bosses to keep real unions out, has finally come to see the light, forming a true union.

For example, the company unions once formed for Standard Oil workers, have mostly become full-fledged labor unions. The country is full of examples.

\* \* \*

Well, soon comes another Labor Day.

Let us mark it well a great day of LABOR.

Let us contemplate, let us think, let us try to see for ourselves the great and growing stature of labor in this nation of ours.

Let us contemplate what labor may contribute to the growth of our nation and to the soundness of free institutions.

A great struggle is being waged between the ideals of freedom and the ideas of the police state—the totalitarian state.

Labor had helped to make this nation one of free people. From unwilling powers it has wrested great laws to safeguard freedom for the men and the women of our country.

Far back in the beginning, labor helped to win and make permanent our system of free public education. Labor was weak then, but it made its voice heard. Labor marched on, winning one freedom after another. Labor has something to celebrate and to commemorate.

\* \* \*

Here is a fact: No evil can long endure if labor is determined to end that evil.

The hateful sweatshop went down before labor's pounding. The injunction gave way. If it sticks one ear above ground again in the Taft-Hartley Act, be assured that time is on the side of right and labor must win again.

Labor has lost battles, but in the whole war, Labor is far ahead.

Labor has had, too, its little crooks, its boils and festers. It still has some of them.

But over the Labor Movement as a whole there flies a banner of integrity, of great idealism, of practical achievement, through honorable means. That banner is the guide for the Labor Movement.

Fly that banner high this Labor Day.

Pay tribute to the labor heroes of the past; pay great tribute. Look forward to the goals of the future and make deep resolve to march on to the attainment of those goals. Think large, plan large—and large it will be!—CMW.

## NABET EMPLOYMENT SERVICE

Due to the day-to-day changes in status and availability of unemployed NABET members, it has not been deemed practical to publish such a list of names in each issue of the Journal. Instead, each available member should immediately notify the National Office, with copies to his Chapter Chairman, of availability together with brief resume of experience, etc., and notify them immediately of any change in status or availability. The Chapter Chairman for the area, and the National Office, each of whom are called upon to fill vacancies, will thus be kept up-to-date to the mutual advantage of all concerned.



is the *only* union of broadcast engineers whose sole concern is the welfare of the broadcast engineer.

NABET invites inquiry from all Radio-TV men who are fully convinced of the futility of the IBEW as a haven for Radio-TV men.

To save your job in Radio-TV, you will have to have the courage to sign a NABET Union-Authorization Card, which will be provided by any NABET Officer (see list page one). IBEW radiomen from coast to coast are contacting NABET. Be organized among yourselves and designate a committee to provide the liaison with NABET. In NABET, the Radio-TV man's interests come FIRST.

NABET guarantees AUTONOMY for the Radio-TV man. Contact NABET today!



## NLRB Votes Against Its Counsel in Complaint Jurisdiction

The National Labor Relations Board has decided unanimously that, under the Labor Management Relations Act, it has discretion to accept or refuse jurisdiction in unfair labor practice cases. This applies regardless of whether the complaint is against a labor organization or against an employer.

The Board's decision on this point was made in two orders dismissing complaints of unfair practices because the business involved were "so small and so local in nature that the interruption of operations by a labor dispute could have only a remote and insubstantial effect on commerce."

In making the decision that it has this discretion, the Board overruled a contention of the NLRB General Counsel that the law gives the Board no power to refuse jurisdiction in an unfair labor practice proceeding if the case affects commerce to any degree.

Under the Wagner Act, the Board exercised its discretion to refuse jurisdiction over certain types of cases on the ground that the handling of these cases would not "best effectuate the policies of the act." In its decision, the Board found that it still retains that power.

### Find No Support

The opinion said:

"We find nothing in the amended act, or in its legislative history, to support the General Counsel's contention that the separation of the judicial and prosecuting functions of the agency precludes the Board members from exercising discretion to decline to assert jurisdiction if commerce is in fact affected. The separation of functions was accomplished by creating the statutory office of General Counsel, with the specific duties and authority set forth in section 3 (d). In other respects, the powers possessed by the Board under the Wagner Act, insofar as here relevant, remain unchanged. In our opinion, section 3 (d) cannot be interpreted to oust the Board of power to determine its own policies for effectuating the purposes of the act."

The General Counsel had argued before the Board that the present act's separation of judicial and prosecuting functions "precludes the Board from refusing to assert jurisdiction in the complaint cases when jurisdiction in fact exists under the commerce clause." Pointing out that the present act gives the General Counsel "final authority" over the investigation and prosecution of unfair practice cases, the General Counsel added: "The concept of discretion to assert or reject jurisdiction on policy grounds is incompatible with the General Counsel's final authority."

### Intent of Congress

On this point the Board said:

"Nothing in the act or the legislative history indicates that the Congress concluded that only the General Counsel had the wisdom to determine what would and what would not effectuate the statutory policy. It is clear that the General Counsel alone was to exercise discretion as to the issuance of complaints, but it is equally clear that the General Counsel's judgment was not to control the Board at the decisional stage of any proceeding. Separation of functions was evidently intended to bar judges from being 'prosecutors'; surely Congress was not seeking, by the same provision, to convert prosecutors into judges."

## The IBEW Give-Away

*electrical union*

is daily being abandoned by

**RADIOMEN**

**NABET**

*is a*

**RADIOMAN'S UNION**

**NABET guarantees Autonomy**

**NABET**

**OFFERS ONE UNION FOR RADIOMEN**

**Join NABET**

The NAB and its anti-labor attitude turns out to be the strongest answer to the broadcast engineer who would ask, "Why should I belong to a broadcast technicians' union?"

The solution to the broadcast engineers' problem of honest, competent, and highly specialized union representation requires a single national union, if their place in radio is to be bettered.

NABET is the *only* national union created expressly to serve the broadcast engineers and technicians.

**Switch to NABET**

---

The Board's rulings were made in two cases, both involving small photographic concerns. In one, involving the A-1 Photo Service at San Pedro, Calif., the Board dismissed charges filed by the company against a local of the Retail Clerks International Assoc. (AFL). The company had charged that the union refused to bargain in good faith and had restrained and coerced its employees. The company, which employs three clerks had total sales amounting to \$133,000 in the year ended March 1948. All sales except \$2,600 worth were made to retail customers within the State of California. The employer purchased approximately 44 per cent of its supplies outside the State during that year.

In the other case the Board dismissed charges filed by a local of the Portrait and Commercial Photographers and Photo Finishers Union (AFL) against the Pereira Studio at Tucson, Ariz., that the company refused to bargain in good faith and had restrained and coerced employees.



## ABC—New York News

By  
**GEORGE  
HALVONIK**

The usual meeting place of the NY Chapter Council is the Hotel Plymouth. They met there on Monday, July 25th. Chairman STOLZENBERGER, as usual, presided over the meeting. Present, were: PETERS—NBC Day Studio; MARTINDALE—NBC Sound Effects; Miss PERRY—ABC Communications; O'NEILL—ABC Day Studio; CLEMENTS—Master Control; O'LEARY for ABC Nite Studio; HAYNES—NBC Maintenance; HACKETT—ABC Field Group; RYNACK—ABC Traffic; MOON—Bound Brook; FITLER—NBC Recording; TERRY ROSS—ABC Sound Effects; CONWAY—Muzark; SIELSKI—WJZ TV Transmitter; MILOS—WNBC Transmitter; PAINE—NBC Nite Studio; CHAMBERS—Assistant Secretary.

The Council voted modest raises for the chairman, treasurer, secretary, and assistant secretary, in recognition of the results achieved. Treasurer Youngster has been getting out his regular monthly financial statements promptly, and Secretary Paine and Ass't Secretary Bill Chambers are keeping up at the secretarial end.

Rudy Bauer, our second executive officer, is now back from a Texas vacation, and he will take an increasingly active part in the administration of the Chapter.

President McDonnell has appointed Chairmen Fred Sperr of WOR; Hudson, Shultis of Engineering, and Stolzy, as the One-Chapter Committee. Fred Sperr wrote a scholarly reply to the recent IBEW 1212 tirade relative to WOR; with One Chapter, we'll get better acquainted.

DeWitt C. Shultis is a name well known for NABET accomplishments. We will run his biographical sketch and photo soon, for the information of the newer members. For a quick run-thru, he is former Maintenance and Field Councilman and Chairman of the New York Chapter about 1937-1938, former NABET Vice President and then President, and now Chairman of our Engineering Chapter, with a membership of 250 or more ardent and active NABET members.

Every radioman should read Chairman Fred Sperr's report on the CBS-NY-IBEW vs. the NABET-NBC contract.

ABC Studio Councilman elections: John O'Neill for Day Studio, Bob Ward for Nite Studio.

The IA is back in our hair again. A report from the Omaha Chapter indicates the IA trying to muscle in at WOW. The IA representative told WOW management that they had reached an agreement with NABET regarding division of jurisdiction in TV. WESTOVER settled that immediately by notifying WOW that NABET expected 100% observance of the contract which gives NABET 100% TV jurisdiction, and to ignore the "IA" lies.

National Representative GEORGE MAHER reports that; "WLAV in Grand Rapids, Michigan has become affiliated with

NABET and the NLRB has held an informal conference to determine whether or not all interested parties would consent to an election being held. The station presently has a contract with the IBEW which expires in November 1949, and we are hopeful that we can convince the Board that such a contract should not be a bar to our eventual certification and an eventful election being held."

An interesting report on the radio situation in Washington, from National Representative CLIFF GORSUCH; "The radio picture in Washington (always a poor radio town) has deteriorated to the ridiculous situation of 27 stations of all types in the area, with rate slashing and downright dishonest practices predominating the advertising picture. The willy-nilly practice of the FCC in granting licenses to almost all qualified applicants is placing the industry's employees in the position of contributing to the financial underwriting of their company's radio enterprises by foregoing wage increases just because there are too many broadcasters on the air for the available number of advertising dollars. It is easy to predict failure and deletion of a great many of these stations if the general economic situation becomes much tougher."

LARRY FLAVEN, ABC Chicago Engineer, traveling with the Hormel All Girl Corps, paid us a visit a short time ago. They did a couple broadcasts out of Radio City. Imagine, traveling around with approximately 80 ex-service girls. But, LARRY is married and has to take his wife along with him. Too bad, LARRY.

Speaking of traveling, TONY HUTSON is still on that world tour with Town Hall Meeting. Probably somewhere in India now coming into the home stretch. Some fellows get all the breaks. For instance, JACK KELLY, a Studio Engineer, toured a good part of the US with the Old Gold Amateur Show. JOHN BOURCIER, Field-Engineer, accompanied JACK on most of his out-of-town trips.

Last March they left a blizzard in NY to go to sunny Miami. There in their leisure time they did some sight-seeing, swimming, and deep-sea fishing. On the fishing trip JACK got an over-does of the sun. BOURCIER administered his "Secret Sunburn Solution,"—a mixture of linseed oil and lime water. KELLY said it worked fine. With a shot of gin it would make a good drink, then you wouldn't care if you were sunburned or not.

From Miami to St. Petersburg to Houston, Texas. In Houston they met JIM DOUGHERTY, ABC Chicago Engineer, who was there with The Breakfast Club Show. LARRY WILLIAMS, ABC Field-Engineer, surprised them by appearing on the scene. He came down from NY to cover the opening of the Hotel Shamrock on St. Patrick's Day. Do you NBC men remember the opening of Hotel Shamrock?

From Texas back to New York. JACK went to Columbus and Indianapolis alone. BOURCIER traveled with the Art Mooney Show to Rochester. But they were back together again to Boston and Niagara Falls.

The next trip with the Amateur Show took them to Denver, TED MACK's home town. There the show played to a capacity crowd of 13,000, packed into a small auditorium. From Denver they went to Omaha and then to Kansas City. Like any two good loyal Americans they visited President Truman's home town. I don't know how it happened, but KELLY sprained his back in Kansas City. Maybe it was from climbing out of swimming pools. Anyway, BOURCIER had to rub him from Kansas City to Chicago!

JACK's final trip was to Atlantic City. LARRY WIL-

To Page 15





## NEW YORK—By Bob Zweck

Tapeworms taking over.—This is the way the less reverent among us refer to the debut of the New studio 2C—2C, the studio that will always retain a fond place on our list as the home of the international broadcasts—Remember?—"Ici parle la voix de la Amerique,"—and "Gooten Tag Sverge" and also "Ir sprecht Amerika"—and the too familiar call on the SOS: "No engineer in 2C!"—Well, those are things of the past. The NEW 2C is the home of TAPE (editing, dubbing and playback).

In one of our past issues, we mentioned the adoption of tape by the net as a means of providing the flexibility for building better shows. Well, the baby's here and gives all indications of growing into a big one. With this added assignment, of course, comes a change in personnel assignments. Hal Schneider of recording, and more recently of field, has been assigned to 2C. Hal has had experience handling tape both in recording and field. Because of his work there and at the political conventions he was instrumental in the design of the new RCA tape machines now being used in 2C.—Along with Hal in 2C, will be Dud Connolly, who moved down from the tape assignment in the newsroom. Rounding out the "crew" will be Jack Kennedy, who has been doing a bang-up job on the Brokenshire show (both of them), and yours troolei. Jack, by the way, will be replaced on the Brokenshire show, I am told, by Peters and Peterson (no relation here). Saturday, July 30th, saw the first show aired out of X 2C. Titled "Americans, the world over," it was recorded in Vienna by ABC's Tony Hutson, flown here by Wright's invention, and played back by NBC's "yours truly"—and did I sweat!—I hear that Johnny Corbett, formerly of recording, is now assigned to the tape spot in the newsroom vacated by brother Dud. Gus Sisko and Johnny will alternate on tours of duty.

Vacation time sees Bob Johnston leaving for that long awaited cruise on his little old yacht. Pressed for an interview just before leaving, Bob would just say: "No Comment." But, we did manage to learn that his plans include visiting waters off the New England coast. Plenty of fishing, sunning, and just lazying on deck. Oh, to be rich! I should've asked him to bring back a mermaid for the lounge—why *one*?—several!!—Hank Kenny of MCD back from his vacation, tanned, refreshed, and rewarded with a mess of fine photos and happy memories.—Sweet an lovely Winnie Mullins, secretary to Mr. Gallant, took part of her vacation down Bermuda way.

To Page 16

## ABC-NY—from Page 14

LIAMS accompanied him on that one. KELLY can't wait for October to roll around so that he can be on the move again. You may have noticed that there has been no mention of women on any of these trips!

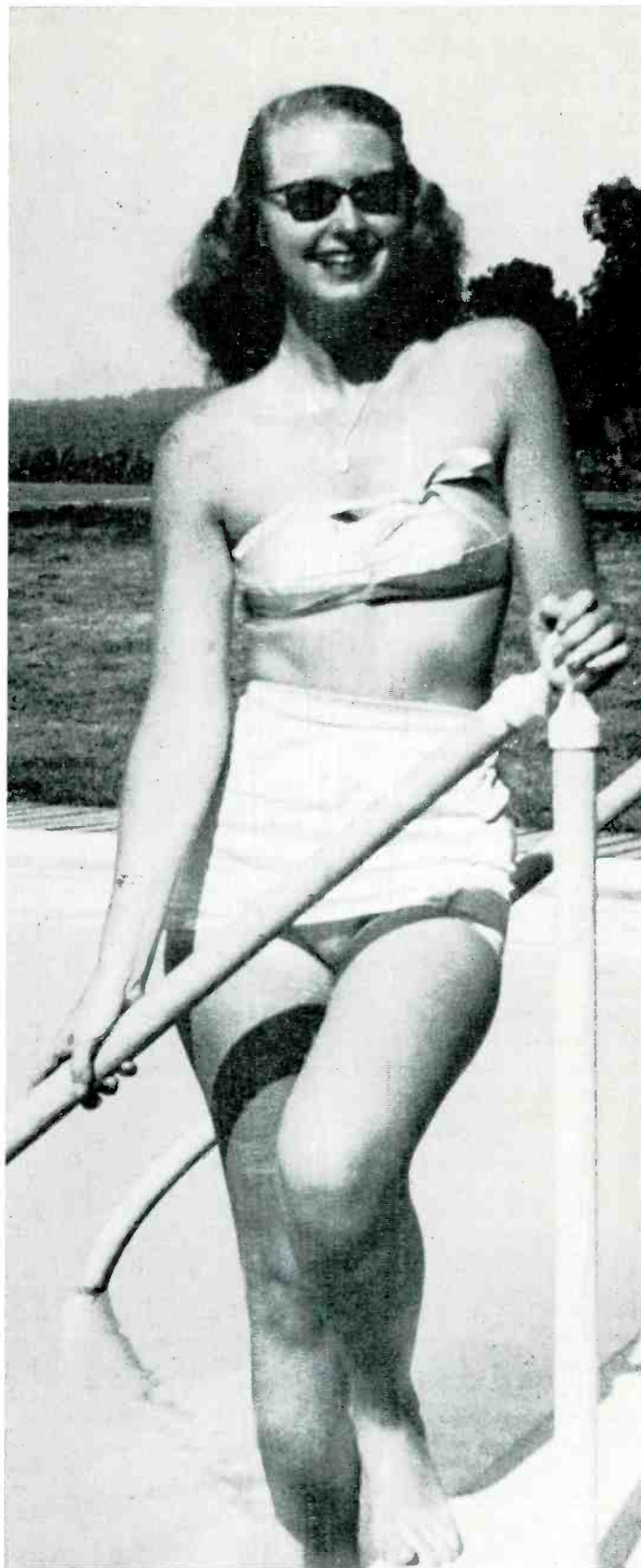

YOU'RE LOOKING IN THE WRONG PLACE.  
SEE TEXT!



# DETROIT

By RED LEWIS

Detroit, NABET's fastest growing chapter, has uncovered a new prospect for National Representative George Maher to sink his teeth into. A powerful CIO local here in town decided they needed more facilities to air their views and they prevailed upon FCC for a CP. The result was the erection of a new FM station, WDET.

Why it was necessary to sign a labor contract with a rival union has not been determined, but an uncertified contract was negotiated with IBEW for engineering personnel—then the men were hired!!

The present situation, in a nutshell is that all five engineers, including the acting-chief, have signed NABET cards and a hearing has been set for August 1.

The Flint, WTAC deal, is even more laughable despite the hardships that are being forced upon its veteran staff of technicians. Four of their men with several years of service with the company were fired for incompetence three weeks before the election date, and given *two weeks notice!!*

The purpose behind this maneuver by management was to leave only three NABET votes on the staff and to bring in the announcers to the election on the grounds that their turntable duties qualified them as technicians.

Subsequently, one engineer was rehired, due to management's inability to find "better men," but not till after the election. That affair was a shambles. NABET objected to all announcers votes and Management challenged the votes of those men who had been relieved from duty. The three remaining unchallenged votes were all NABET.

But all is not back-stabbing and throat-cutting in Detroit. This Chapter had the honor of sponsoring what is hoped will be the first of an at least annual social affair for the benefit of all radio personnel in the area. The Chapter provided a good hall, the best musicians in town from the staff of WWJ, and a really good spread of food and drink. A reasonable admission was charged and, altho expenses were not quite met, the Chapter feels the money well spent. The greatest obstacle to overcome at present is the fear of quite a few that the event is a union dodge to propagate.

## NEW YORK—from Page 15

Sailed down and flew back. Asked about the MALE situation there, Winnie replied: "Entirely satisfactory!"—Ummm—Almost walked right by Carl Lindemann, of TV, 'other day sans recognizing him.—Talk about RED men. Don't know where he went on his vacation, BUT what a tan.

This month's contribution to the "Miss Broadcast Engineer" gimmick, sees Miss Anne Szigethy making her debut. Data: This 5 ft. 10 in. blue-eyed blonde is the secretary to Mr. Jacobson, field supervisor. Hopes to remain there 'till "the right one comes along." As the pic indicates, she likes swimming; also dancing and bowling! What has Hollywood to say to this? Tongue-tied?

Some of you out-of-town people may be familiar with the "automats" here in NY; certainly most of the Radio City boys are. Whatever your past impression, believe me, not all of the novelty and attraction lies behind those little glass windows on the wall. The continuous parade of CHARACTERS thru that place would provide material for any comedy series, especially on video.



# HOLLYWOOD

By NORMAN DEWES

What's this guy Zweck of New York trying to do? To meet the competition, we are offering a jackpot prize to each reader of this column who agrees that our gals surpass the New York variety. The release that came with this photo says: SHEER BEAUTY—A girl as beautiful as Nina Bara needs no reason to be photographed other than her languid beauty. Nina, as fine an actress as she is a beauty, frequently is heard on ABC's "Mr. President" series. Photo herewith.



## Maine's Equal Pay Law

In Maine, equal pay for women for equal work in any occupation within the State is required by an act approved April 25, 1949, which prohibits discrimination in salary or wage rates because of difference in sex.

The law, however, expressly provides that variations may be made in such pay rates when based on differences in seniority, experience, training, skill, ability, duties performed, shift or time of day worked, availability for other operations, or other reasonable differentiations.



## ST. LAWRENCE

By ALEEN A. CORBIN

What do you think of our new column heading? (If it got there in time to be printed with this article. If it didn't, you'll just have to wait breathlessly until next month to see the new, new look.) It was all my father's idea. He is a printer, or rather a pressman, for a local printing company. One of their jobs was to print thousands of these on picture post cards for some company in the Islands. A proud father, he reads my articles with more gusto, I'm afraid, than anyone else, and he is always making suggestions for making them look better. Once in a while I actually take some of them to heart. So when he suggested he might be able to get a cut of the picture he was using, everyone here thought it was a good idea. His boss kindly gave consent, and now we, too, can be identified by something besides the title and the inane contents of the material.

The beautiful young lady whose picture accompanies the article this month is the daughter of William F. Willig of WMSA and WMSA FM, Massena, who was kind enough to send down some information about our other chapter member. Ray Bistany, who usually sends me stuff from up there, was very busy with contract negotiations for that station, so he kindly passed my letter asking for news along to the other guys, and they were good enough to send some stuff along. With the help of Stan Ivill for backing, Bill tells me that their FM tower is 383 feet. The station operates from 3:00 p.m. to 9:30 p.m. daily with an output power of 13 kilowatts. At this time most of the broadcasting is simultaneous with the AM station using a double break.

Ray was married April 30, 1949. On their wedding trip the couple traveled through the New England states and even up into Quebec. Bill says Ray wanted to

see as much of the world as possible in a couple of weeks. He doesn't know from just what source this yen for traveling stems, but he comments, "He never did get over his hitch in the Army." Ray and Mrs. Bistany are home now at 9 Stearns Street, Massena.

Stan Ivill has not done anything so permanent as getting married—yet. But Bill tells me that he is engaged to a local girl, and the fiends with whom he works are doing all they can to make sure this becomes a permanent relationship. I'm not quite sure if this comes under the adage about sharing good things or misery likes company, but at any rate, Bill says all the fellows are hoping for the best of luck for Stan and so are we.

Bill and his lovely wife and charming daughter reside at 68 East Orvis Street, Massena. He claims Buffalo as his home town. Four of his five years' experience was furnished by the signal corps in the



Army. Later he spent some time with Westinghouse before coming to the station. He attended Central Radio and Television Schools in Kansas City, Missouri, graduating in 1948 after completing the radio and television course. Bill says that the gang up there has convinced him that his daughter is the prettiest little girl they ever saw. It was a tough job to do, but they finally made it. However, being a father, Bill realizes that such a statement is liable to start some sort of major controversy, so just in case it should come he has forwarded the evidence and will rest on that. Bill adds that normally he is not a secretary, but he was elected to this position by a majority vote. That is, both Ray and Stan looked at him and said, "You're elected." I'm sure there are many of you who know just exactly what Bill means.

Now, about those negotiations that I mentioned briefly a while back. Believe it or not, it has been three years this August that our chapter was created, and a short while later that I began to inflict this sort of thing upon you. After the first year everyone still felt that the contract was more than adequate, and no one was anxious to open. Last year, despite some feeling that we should make some demands, the majority of us felt that the time was not expedient to do so. However, this year, in view of last year's election, the unprecedented high cost of living, etc., the greater share of us decided that this was the time to do a little bargaining. Dave Lane, George Gebhard, and Bill Walck represented WWNY and Ray Bistany was here for WMSA. All of these guys worked hard and really did a fine job making points that helped to put across the argument. But it was the Union representative, Mr. Harry Hiller, who really did the job for us. The boys say his work was nothing less than superb, and that, if it hadn't been for his ability and tact, they don't know what would have been the outcome. However, they have a horrible feeling of what it might have been. Fortunately, Mr. Hiller made all worries of what might have been a thing of the past. His diligent efforts secured for us, all of us, a raise in pay, a union shop, and union security, a thing that makes us all feel a lot safer.

Some new men have been added to our own engineering staff, something of an event for us. John Wicks came to fill the void when Caroline Ryan became Mrs. E. James McDonald, Jr. Johnnie came to us after spending the last nine years in service with first the Air Corps and then the Navy, a graduate from the U. S. Naval Academy with a B.S. It has only been the last few months that he has become interested in radio, but he is doing nicely.

I don't know if I mentioned Bob Pratt last year or not, but Bob is the part time engineer who works with us in the summer. He gets sort of a rough deal having to work so many different schedules, but he accepts all changes like a veteran. Bob was graduated from St. Lawrence U. with a B.S., majoring in mathematics, this last June. A few days later he was married to one of the girls he had met on the campus. In the fall Bob is going on to R.P.I. for a Bachelor of Electrical Engineering degree. About this he is very happy. However, he is not quite so elated about the fact that his very nice wife will be a senior this fall at S. L. U., majoring in sociology, and she could not transfer without losing at least a whole year. This



means that they won't be able to see too much of each other from fall until next June. This is a rather sad prospect for them as you can see.

Outside of the fact that various people are taking vacations, everything here is very quiet. Most of the people who do go on vacation stay at home, rest, and fix up their houses now that most of the fellows are landowners. Bill Walck went to New York and to his home in Pennsylvania early in June. Bob Bouchard took his family up to Boston to visit Mrs. B.'s folks, and the same is true for the Maynard Davises. Gail Pfister is on vacation now with husband Mo, who is a student at S.L.U. summer school. The AM xmtr. is being redecorated inside. This is only because it *looks* as if it needed it, despite Winnie's experience the other day. Winnie, you may recall, is the German Shepherd dog belonging to Bill Walck in name only. Actually she is the property of the xmtr. boys. The other day Bill thought he saw a woodchuck and sent Winnie after it. A well-trained dog, Winnie obeyed. As soon as Bill saw his mistake he shouted for her to come back, which she did. But not soon enough. However, not too much damage was done, or, perhaps I should say that the damage was not as pronounced as it might have been. I repeat, though, that the redecoration was undertaken solely to improve the looks of the place.

The R.I. was through the other day, but he found everything in shipshape order.

A few months back Bill Chambers, formerly of the station, and now a member of NBC dropped in to see us while he was on vacation. A very gracious liar, Bill says he enjoys the column. He also asked me the same question that a couple of the engineers here have asked me whenever I have returned from a trip to New York City. Why don't I visit the office down there and one of the stations? I've told them that I was afraid that everybody was just being polite. Actually they probably hate to have to take time off to be polite to some visiting yokel, when there are so many other things which they would rather be doing. But Bill assured me that this would not be so. That he at least, and he's sure everyone else would be happy to show me around, and that it would be no trouble. I'm hoping that I'll be able to get down around Thanksgiving, and I'll show him. I'll take him at his word. I've seen a couple of network shows from the audience, and I've always wanted to know more about the workings. It *looks* fascinating.



## WASHINGTON

By W. D. DEEM

The boys from the WRC transmitter report that a new set of apartment buildings might be going up close by. This will mean a new radiation pattern at the transmitter due to the steel construction of the new buildings and may mean relocating one of the antennae. At any rate *Mike Galvin* tells me that he saw engineers surveying the site for the new buildings.

*Al Sears* besides being a good WRC maintenance engineer is also a first hand horticulturist. His prize winning royal purple gladiolas, named "Vagabond Prince," are real beauties. Some of the blossoms on these glads are as tall as 1½ feet and each bloom is a masterpiece in itself. *Al* recently returned from a vacation out West. He stopped in to see the engineers at the Chicago NBC station. The receptionist thinking he was just another "layman" visitor called a page boy to take *Al* and party on the 50c tour. *Al* politely dismissed the boy and called the MC desk, got the engineer on watch and was soon on the inside where he wanted to be.

*John Neff*, of WOL, and wife went on a foreign vacation this year, all the way to Mexico. *John* said he noticed that there is very little activity in television out west. Denver has a station ready to go on the air, might even be on the air by the time this is in print. Mexico City has been granted a CP and will soon have a TV Station. *John* stated that it was like going through another world—hardly any TV antennae were to be seen protruding from the roofs of the homes along the way. Jobs aren't as easy to get out that

way which may be one of the reasons for the slow growth of television.

New cars seem to be a popular topic wherever I go to get news for the journal. *Wally Bush*, of NBC finally got his new Pontiac. A few weeks ago he received a call that his new car was ready for him. He hurried down and saw the car. It had everything he wanted right down to the color of the upholstery, but had a standard gearshift instead of hydramatic so *Wally* went on his vacation minus a car. Now his hydramatic is here and he is a happy owner of a new car. Other new car owners are: *Bob Terrel* of NBC, new '49 Packard; *A. H. Hallam* and *H. Reed* both of WOL have new Buicks; *L. Parrish* of WOL, new Kaiser; *H. L. Stark* of the WOL transmitter was last reported a pedestrian, but is patiently waiting for his new Plymouth. At NBC *Ed. McCaul* now owns (he and the Finance Co.) a new Studebaker.

*Bob Shenton* and *Ruth Collins* of WRC have set the date for Sept. 26. *Bob's* new home is nearing completion and *Bob* and *Ruth* plan a honeymoon trip to the New England States this month.

WRC and WMAL studios look nice after a recent face-lifting and the addition of new turn tables. It used to be set up so the turn tables were in back of the operator and a fellow had to have either four arms or two exceptionally fast ones to put on the average record show, but now both the turn tables are at an angle on either side of the console making the stations much more efficient.

If any of the members of Washington or nearby Md. or Va. NABET are interested in flying they should contact *John Neff* at WOL, Me.-0010, for all the dope about a new flying club recently formed called the "Sports Flyers Inc." Very inexpensive flying.

And that's all from Washington at this time.

If It Concerns

The Broadcast

Engineer



—he will read it in the

BROADCAST

ENGINEERS'

JOURNAL



## IRE from Page 9

perimental system gave surprisingly good results with three or four digits. No conclusions are drawn as to the number that would be required in practice.

### SYMPOSIUM: RADIO AIDS TO NAVIGATION

Chairman, H. BUSIGNIES

(Federal Telecommunications Laboratories, Inc., Nutley, N. J.)

#### 1. The Radio Technical Commission for Aeronautics—Its Program and Influence.

J. H. DELLINGER, *Radio Technical Commission for Aeronautics, Washington, D. C.*

#### 2. Frequency Allocations to the Aeronautical Services above 400 Mc.

V. I. WEIHE, *Air Transport Association of America, Washington, D. C.*

#### 3. Experimental Multiplexing of Functions in the 960- to 1660-Mc Frequency Spectrum—Its Influence on Weight and Complexity of Equipment.

P. C. SANDRETTO AND R. I. COLIN, *Federal Telecommunication Laboratories, Inc., Nutley, N. J.*

#### 4. The Philosophy and Equivalence Aspects of Long-Range Radio Navigation Systems.

M. K. GOLDSTEIN, *Office of Naval Research, Washington, D. C.*

#### 5. The Future in Approach and Landing Systems.

HARRY DAVIS, *Watson Laboratories, Red Bank, N. J.*

The RTCA is an organization for the co-ordination of effort in aviation radio and electronics. It operates through the preparation of recommendations formulated by temporary technical committees with specific directives. It includes in its membership all interested bodies, both government and nongovernment. These members participate in its support, both technical and financial, and give effect to its recommendations. As an example of its work, it formulated and continues to sponsor the 15-year program of air traffic control and navigation aids whose implementation is now beginning. This work will be described by Dr. Dellinger.

Frequency allocations to the aeronautical services above 400 Mc will be discussed by Mr. Weihe. During 1944 and 1945, aviation electronic engineers, as a result of wartime advances, proposed several very noteworthy integrated systems for the navigation and traffic control phases of aeronautical operations.

During 1946 and 1947 certain development work was initiated, and aviation was confronted with a need for evaluating the systems to find which system or system elements had the greatest merit. Early in 1947, it was realized that additional radio-frequency spectrum was necessary in order to conduct the necessary development work and to provide space for in-

stallation and utilization of the adopted equipments. Frequency service allocations for these services were made by the International Telecommunications Union at Atlantic City during the summer of 1947.

Aviation is now confronted with a need for establishing a complete plan for channel allocations within the available radio-frequency spectrum. Several major elements of the complete plan have already been established and considerable progress toward the ultimate plan can be anticipated for the next two or three years.

A prominent feature of the RTCA plan for the ultimate air navigation and traffic control system is its aim at economizing on equipment and channel space as well as achieving operational simplicity, as expressed in its recommendations for the development of radio equipments which multiplex a number of different navigational functions on each of a series of channels in the 1,000-Mc region. Theoretical studies have been made by other authors to show that the frequency bands available are sufficient to permit the multiplexing of all desired facilities. There is lacking, however, studies of methods for separating the various signals, and this very practical consideration is of equal importance in evaluating the RTCA plan.

The paper by Messrs. Sandretto and Colin describes certain experimental equipment which has already been built and which furnishes data that substantiates the general practicality of the RTCA plan. Results of initial tests are given. A 51-channel narrow-band DME is used as the keystone; upon this there is multiplexed an azimuth or omnirange service, in conjunction with a ground radar, and also a relay radar service for providing an airborne pictorial display.

Means of obtaining interference-free mutual operation of the various functions are described, and questions of duty cycle requirements are discussed. Certain novel features of the equipment are presented through block diagrams and photographs; these include a high-speed combination primary and secondary radar antenna, a two-color combination radar indicator, and altitude coding and decoding features.

The possibility of obtaining the full degree of multiplexing as envisaged by the RTCA plan is discussed in the light of experience gained with this experimental equipment.

Dr. Goldstein's paper will establish a general systems convergence or equivalence principle for all long-range radio navigation systems. It shows that there is an upper limit on the theoretical range and accuracy of such systems. This up-

**100% COMPLETE BULK TAPE ERASURE ON THE REEL —**

**WITHOUT REWINDING!**

**MAGNERASER**  
The Perfect Magnetic Tape Eraser

Erase a recorded reel of tape — faster and more completely! No matter what tape recorder you are using,

regardless of what brand of tape you are using, or how severely the tape is overloaded, the Magneraser will eliminate the recorded signal completely, and bring the background noise level 3 to 6 db. below that of brand new unused tape! No contact with erase heads — means less tape wear.

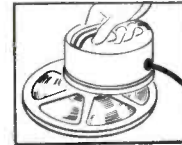

To operate, simply place the Magneraser on top of the reel of tape, and move it around as per instructions supplied. In a matter of seconds, the tape is wiped absolutely

clean of all signal.

Size 4" Diameter, 2 1/2" High; Weight 2 1/2 lbs.; Operating Current 100/130 volts, 25/60 cycles; Power consumption 60 watts. Furnished with 6 ft. cord, molded rubber plug, and operating instructions.

Order today direct from factory. Shipment by return mail. Parcel postage charges prepaid.

List Price ..... \$32.00

Professional Net Price ..... **\$24.00**

ACCESSORIES DIVISION, \*Reg.T.M.

**AMPLIFIER CORP. OF AMERICA**

398-60 BROADWAY NEW YORK 18 N.Y.

per limit is principally determined by the parameters of:

1. Frequency. 2. Average power. 3. Azimuth magnification index (AZMI) (the ratio of electrical azimuth intelligence per degree of space azimuth). 4. Instrumental time constant (ITIC) (the permissible instrumental reading time).

It is further shown that different existing and proposed systems differ essentially in "cleverness factor," i.e., the efficiency with which the permissible azimuth-magnification index and permissible instrumental-time-constant factors are utilized. The azimuth-magnification cleverness factor gives a means for increasing the effective resolving power of the system and a means for reducing the effects of some of the ionosphere and instrumental errors. The instrumental-time-constant cleverness factor gives a means for achieving effective increases in the signal-to-noise ratio. The latter increases is reflected in increased range and accuracy performance, where white atmospheric noise would otherwise limit such navigational performance.

Present research and development activi-

# Rocky Mountain News

By GEO. SOLLENBERGER

From the wild and woolly west there is not much of news caliber except that there are still many people coming to see the mountains, Sketches in Melody, and Mae West who is presently attracting even bigger crowds up in Central City. Plus this, Colorado now has horse, dog, and human races. Even though you bet on any of them, they are still racing for the state. This is proved by the story that one winner of a nearby nag trot who thought he had just won \$42 and by the time he got hold of the green stuff there were only nineteen of the little marching men. Of course the local boys generally go elsewhere to see TV, in California or Salt Lake and don't bother with racing. Transmission of TV in the 420 mc. ham band will soon be a reality as Video Associates hope to have a picture to be used with some of the kit receivers using converters to achieve reception of the higher freques.

Al McClellan traded off the old klunk for a shiny Plymouth sedan and Kenny Raymond traded his Ford for another much newer and prettier. There are still a few who have to succumb to the urge to buy a new buggy but there are the vacations and other miscellany to think about, too.

Aubrey Blake, our new chapter chairman, is doing well in his realm, in fact so well that he appointed yours truly to *Yearbook* staff. Seems early to be thinking about Christmas but the yearbook is really a work of art.

All concerned are glad that the tape conflag is finally settled. Dick Parks from San Francisco favored us with his presence at a most opportune time. He also gave us an outsider's viewpoint on the situation at hand. Thanks Dick.

Though short, that is it from our chapter.

## IRE—from Page 19

ties in approach and landing systems for aircraft indicate the type of electronic landing aids which will be employed in the future common systems of air navigation. Starting with an analysis of presently used systems, Mr. Davis will present a review of the newer developments with emphasis upon techniques used to eliminate present deficiencies. Included in the discussion is material on automatic ground-controlled-approach radar equipment and fixed beam systems.

## ACTIVE CIRCUITS

Chairman, JOHN R. RAGAZZINI  
(Columbia University, New York, N. Y.)

### 68. G Curves as an Aid in Circuit Design.

KEATS A. PULLEN, *Bullistic Research Laboratories, Aberdeen Proving Ground, Md.*

The use of G curves for design of electron-tube circuits offers several distinct advantages over present methods. These include simplification of theoretical approach and a more flexible circuit-design technique. Although basically the method gives only small-signal amplifications, use techniques will be presented which make design for large-signal conditions routine. The basic approach and considerable application data will be given.

### 69. A Direct-Coupled Amplifier Employing a Cross-Coupled Input Circuit.

J. N. VAN SCOYOC AND G. F. WARNEK,  
*Armour Research Foundation, Illinois Institute of Technology, Chicago, Ill.*

A high-gain direct-coupled amplifier employing a newly designed cross-coupled input stage is described. The amplifier has an input impedance of 100 megohms and a gain of 500 to 50,000, variable in 2-db steps by the insertion of negative feedback. Either single-ended or push-pull input may be employed, while a low output impedance is obtained from a cathode-follower output stage. The upper half-power frequency limit varies from 50 kc to 150 kc, depending on gain setting. Power requirements are low and miniature tubes with ac-operated heaters are used throughout. A preamplifier is built on the same chassis and can be simply connected to the dc amplifier input through a coupling network with a large time constant. The preamplifier has a maximum gain of 50 and includes a hum-balancing control.

### 70. Annular Circuits for High-Power Multiple-Tube Generators at VHF and UHF.

DONALD H. PREIST, *Eitel-McCullough, Inc., San Bruno, Calif.*

A new type of vhf and uhf circuits or cavity known as the annular circuit is described, and various ways of applying it to multiple-tube generators using negative-grid tubes are discussed. The properties of annular generators are examined, and they are classified with other older types of multiple-tube generators. It is shown that there is no fundamental limit to the number of electron tubes that may be used in such a generator, and that the efficiency versus frequency characteristic is the same as that for a single tube and circuit. The influence of the annular circuit on design of the component tubes is discussed, and a survey of some possible applications in

the frequency range 100 to 1,000 Mc is made, with special reference to high-band television.

### 71. Considerations on Electronic Multicouplers.

W. R. AYLWARD AND E. G. FUBINI, *Airborne Instruments Laboratory, Inc., Mineola, L. I., N. Y.*

An electronic multicoupler is, by definition, a device which, when connected to an antenna, can feed rf energy to a multiplicity of receivers without introducing undue sensitivity loss, crosstalk, spurious responses, or overload. The basic criteria which must be made a basis for the design of multicouplers will be discussed, such factors as band-width, receiver noise figure, variations of antenna impedance with frequency, and effects of strong interfering signals will be considered. A new type of multicoupler design which has been used in several units built for frequency bands from 2 to 30 Mc will be briefly described.

### 72. Improved Degenerative Regulators.

Y. P. YU, *North Dakota Agricultural College, Fargo, N. Dak.*

Improved circuits for a direct voltage regulator, an amplitude-stabilized oscillator, and an illumination regulator are described. High stabilities are attained by the use of "constant-current" elements and memory capacitors.

## INSTRUMENTS AND MEASUREMENTS III

Chairman, R. M. BOWIE  
(Sylvania Electric Products Inc., Flushing, L. I., N. Y.)

### 73. An AM Broadcast Station Monitor.

H. R. SUMMERHAYES, JR., *General Electric Company, Schenectady, N. Y.*

Standard AM broadcast stations require continuous monitoring of frequency and percentage modulation, quantities which are ordinarily measured by separate instruments. A new AM monitor will be described which combines these measuring functions into one instrument. The new instrument features a local oscillator which is synchronized in constant phase relation with the carrier component of the modulated signal from the transmitter. The local oscillator signal, in turn, energizes a quartz-crystal discriminator which indicates deviation from assigned transmitter frequency. The local-oscillator signal is also added to the modulated wave from the transmitter to reduce the effective percentage of modulation, thereby eliminating negative-peak clipping in the detector.

---

BROADCAST ENGINEERS  
READ THE BROADCAST  
ENGINEERS' JOURNAL

---



**SHURE "556" BROADCAST DYNAMIC  
PROVIDES "WIDE ANGLE" PICKUP YET  
REDUCES RANDOM SOUND PICKUP BY 73%**

**"WIDE ANGLE" PICKUP**  
*for Greater Performance Freedom*

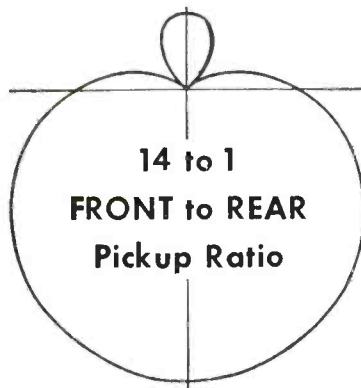

**73% REDUCTION OF  
RANDOM SOUND PICKUP**  
*for Clearer Reproduction*

**Shure "556"**  
**Super-Cardioid**  
**Broadcast**  
**"Unidyne"**  
**Dynamic**  
LIST PRICE **\$92.50**

**SHURE**

**SHURE BROTHERS, Inc.**

*Microphones and Acoustic Devices*

225 West Huron Street, Chicago 10, Illinois • Cable Address: SHUREMICRO



# TWENTY YEARS OF ATTENUATOR PROGRESS

BY

# DAVEN

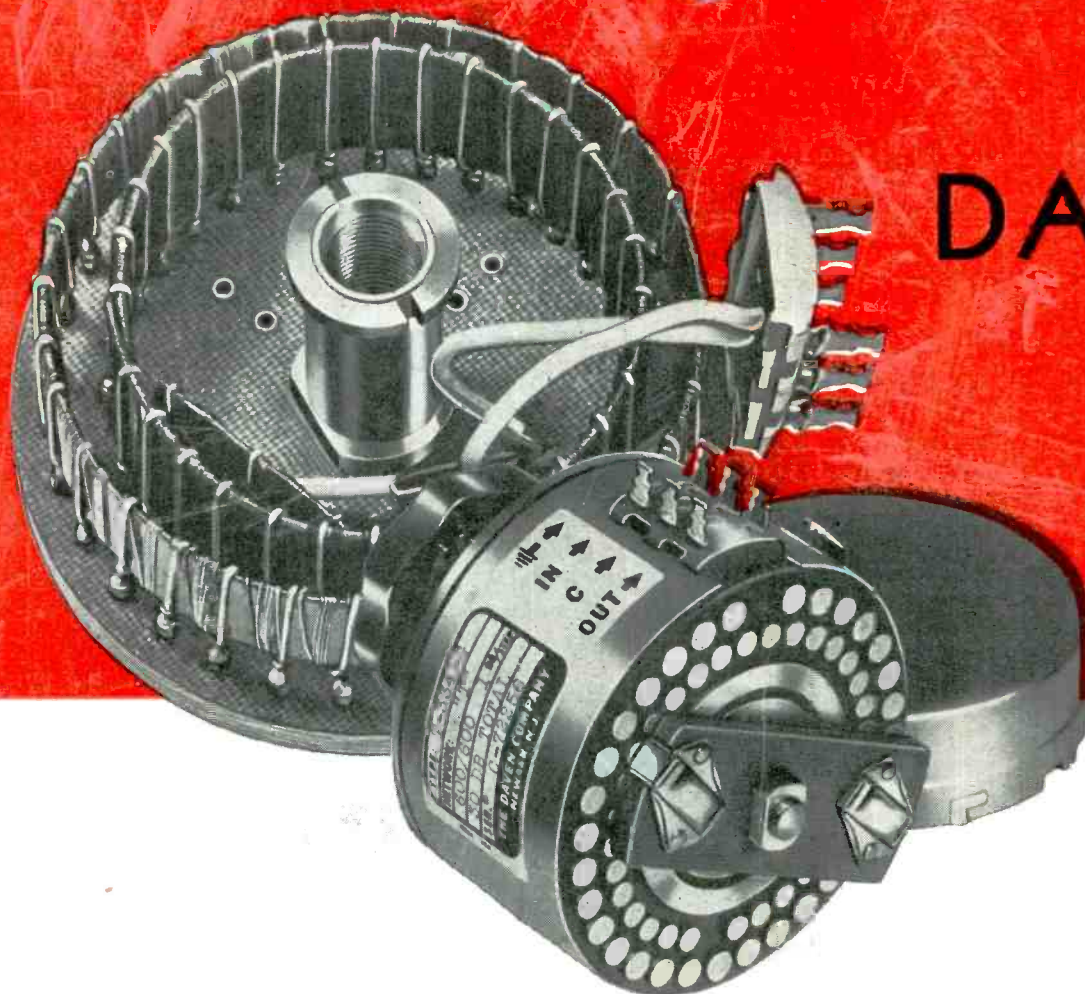

As one of the oldest and most progressive manufacturers of attenuators, we take pride in presenting our recent contribution to the users of fine volume controls. . . the "Knee-Action Switch."\* This revolutionary type of rotor is now being offered on Daven attenuators and switches at no additional cost.

For longer life and uninterrupted performance, we offer a switch with the following advantages:

- ★ Multiple wiping blades of the "Knee-Action Switch" are enclosed in a tamper-proof housing.
- ★ Each blade conductor is individually spring loaded, giving a perfect balance to the entire conducting surface.
- ★ Uniform pressure on the contacts and slip rings is assured, resulting in low, even contact resistance, over the life of the unit.
- ★ The considerably shorter rotor arms, result in lower overall switch resistance, due to the reduced conducting path.
- ★ For specialized switch applications, where space is limited, this new type of switch construction permits up to 6 poles on a 2 3/4" diameter deck. A greater number of poles may now be obtained than heretofore, on all smaller diameter units.

\*PATENTED

For Further Information Write to Dept. BE-5

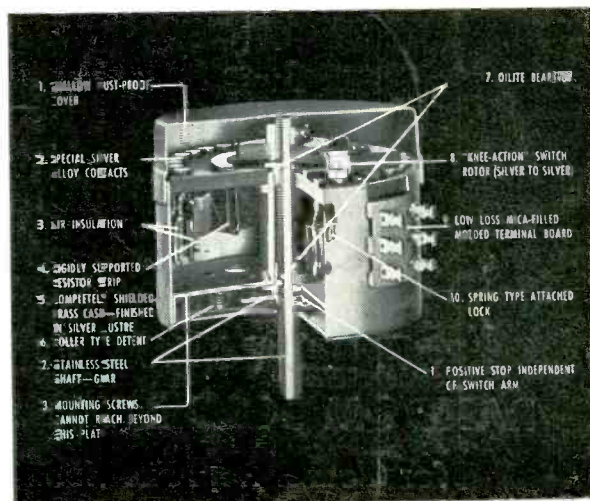



THE **DAVEN** CO.

191 CENTRAL AVENUE  
 NEWARK 4 NEW JERSEY

